

ZOOMONE

ZOOMONE



ZOOMONE+

- ✓ **Tap** payments and preferred rates backed by **Moneris**
- ✓ **Debit, credit, and digital wallet** enabled
- ✓ Easy to install
- ✓ **EMV** certified, **PCI** compliant
- ✓ **Count up** or **count down**
- ✓ Ideal for **self-serve** washes
- ✓ Works next to **coin acceptors** and **rotary switches** via relay or pulse

Powered by
Moneris



1-866-361-7846



Click here to see
the product video

ZOOMONE

Requirements

REQUIRED:

- 4x #6 screws/bolts (to mount unit to surface)
- 110 power to 2 power supply wires
- 2x wires attached to relay switch/external wash selection
- A connection to a rotary switch or external wash selection

Relay Wires – The red wires coming out of the ZoomOne Device connect to the Solenoid Switch or Wash Activation Node, usually labelled “LOAD”. This Relay allows the ZoomOne to turn the wash ON/ OFF.

2 Ethernet Cables in – You must open up the ZoomOne box to wire in the Ethernet (CAT5) cables to the internal router and the store's dedicated internet connection.

Power Wires – The black/yellow wires coming out of the ZoomOne device connect to the internal 12VDC Power Supply. Plugging that power supply into a 110VAC outlet with a **dedicated breaker** will power on the entire unit.

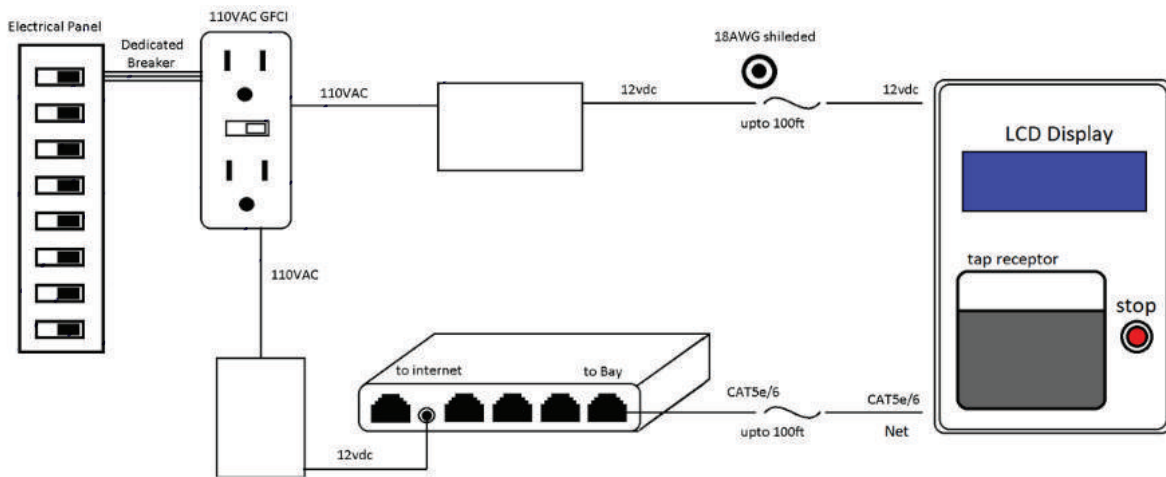
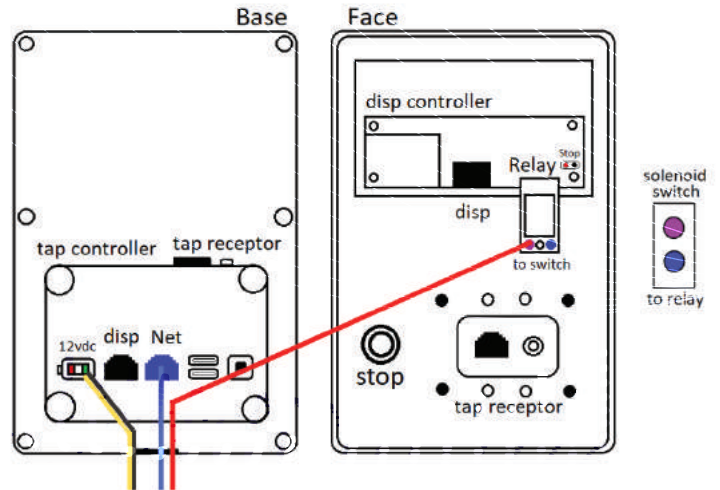

Please note that **Wiz-Tec does not provide installation for ZoomOne unit purchases**. You must use your own electrician or Wiz-Tec can refer an electrician to you. Wiz-Tec will supply all necessary instructions for wiring/installation and will ship the devices as a "plug and play" product. Reporting and merchant account management is done through the Moneris portal.